

# UXL Vehicle Restraint Specification Sheet and Submittal

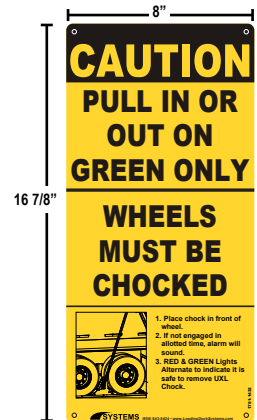

Outside signage

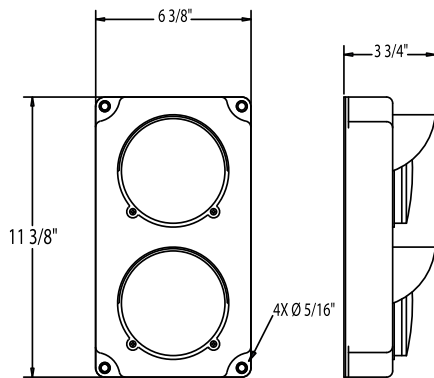
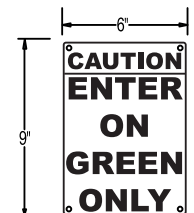

Inside signage

## STANDARD FEATURES FOR THE UXL VEHICLE RESTRAINT

- Universal Wheel Chock with Light Communication System
- Audible Alerts to Ensure Safe Use and Storage
- Interior Messages for the Position of the Chock
- iDock® Alert with Interactive Message Display
- Option to Connect Online with myQ® Dock Management
- Steel Teeth Engage Ground Plate to Prevent Pullout
- Articulated Arm Provides an Effortless Placement of Chock
- Galvanized Ground Plate Provides Advanced Corrosion
- Made in the USA

# UXL Vehicle Restraint Specification Sheet and Submittal

**GENERAL DESCRIPTION:** The DLM® UXL is a wheel-based trailer restraint with advanced light communication and available as a standalone unit or integrated with other dock equipment. Universally effective in most conditions, the unit helps prevent unexpected trailer departure or movement from the loading dock during the loading process. The UXL vehicle restraint features steel teeth that engage ground plate, inside iDock control panel, exterior communication lights and instructional signs.

**CONSTRUCTION:** The restraint unit is durable steel construction with a powder coat finish. The ground plate is galvanized providing advanced corrosion protection. The retracting arm and storage bracket are zinc-plated steel. Wired sensors are installed in the restraint unit and the storage bracket. The control panel is NEMA 4X with all components, connections and wiring UL listed and/or recognized. Panels are built in-house in a UL-approved control panel shop.

**OPERATION:** Once a trailer is fully backed and parked in position against the dock bumpers, the yellow UXL is removed from the storage position and placed under the front of one of the trailer's back tires, locking into the ground plate. A message will display on the iDock Controller that the unit is in a safe position. The dock attendant can then proceed to open the door and deploy the leveler.

After loading is complete, the dock attendant stores the leveler and closes the overhead door, either of which must have an installed switch interlocked with the restraint. This will then display indications to return the UXL to the stored position.

**EXTERIOR LIGHTS:** Low profile, traffic style, red, and green LED lights are standard for communication to truck driver. A set of caution signs warns truck driver to "Back In or Pull Out On Green Light Only".

**ELECTRICAL:** The UXL vehicle restraint is available as a stand alone unit or combined electronically in a single integrated control panel with your dock leveler selection. Interior and exterior 12 volt LED lights are powered by an integral transformer located in the control panel. Electrical control panel is a NEMA 4X enclosure.

**Please Note:** Unless specifically noted on quotation, all electrical requirements, including mounting of control box, outside lights and signs, are the responsibility of others.

**INSTALLATION:** Requires mounting of UXL storage base, control panel, exterior lights and signs in strict accordance with DLM's installation instructions.

**WARRANTY:** All UXL vehicle restraints feature a full one (1) year base warranty on all structural, mechanical and electrical parts, including freight and labor charges in accordance with Systems, LLC's Standard Warranty Policy. Systems, LLC warrants all components to be free of defects in materials and workmanship, under normal use, during the warranty period. This base warranty period begins upon the completion of installation or the sixtieth (60th) day after shipment, whichever is earlier.



Integrated Control Panel Shown  
 (Size varies with options)

### Optional Equipment for UXL Vehicle Restraint (Check options desired)

- |                                                                   |                                                     |
|-------------------------------------------------------------------|-----------------------------------------------------|
| <input type="checkbox"/> Integrated Control Panel                 | <input type="checkbox"/> Special Nema ___ Enclosure |
| <input type="checkbox"/> Restraint Engaged Interlock with Leveler | <input type="checkbox"/> Post Mount                 |
| <input type="checkbox"/> Restraint Engaged Interlock with Door    | <input type="checkbox"/> Other _____                |
| <input type="checkbox"/> Embedded Snow Ground Plate               | <input type="checkbox"/> Other _____                |
|                                                                   | <input type="checkbox"/> Other _____                |

\*Options must also be selected on the iDock Controls specification sheet

Customer: _____ Job: _____ Location: _____ Number of Units: _____ Voltage/Phase: _____ Represented By: _____ SalesRep: _____	Certified For Construction: By: _____ Date: _____ Company: _____ City & State: _____ Drawing #: _____
------------------------------------------------------------------------------------------------------------------------------------------------	----------------------------------------------------------------------------------------------------------------------

SS UXL 12/23

A continuing product improvement process is in effect at Systems, LLC. We reserve the right to make product changes without prior notice.