

Subject: Tough Strut Upgrade

In late 2017, the Allied Solutions Tough Strut was released as a supplementary support for mechanical and air-powered dock levelers. Shortly after release, the Tough Strut base was modified and an additional header support was created to allow compatibility with many hydraulic levelers. This TSB provides an overview of upgrading the original Tough Strut.

Tough Strut - Current Design

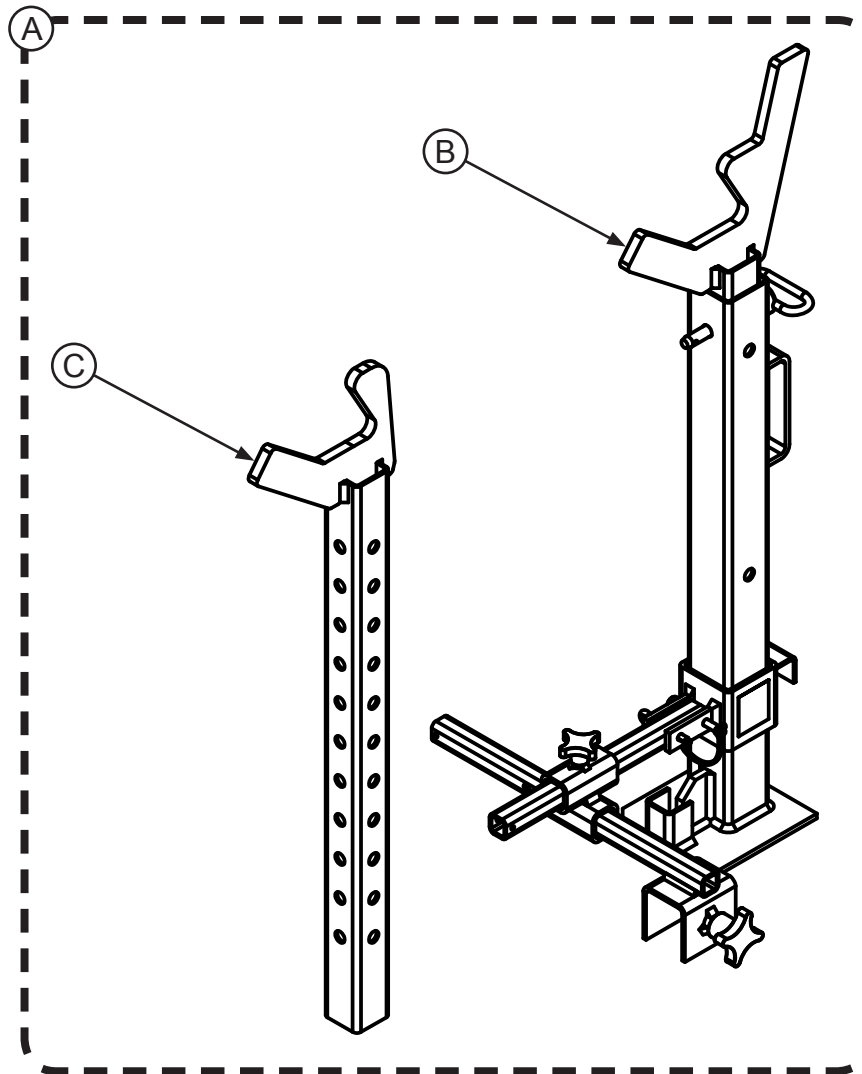

Item	Description	Part Number
A	Tough Strut Kit	9496-0003
B	Catch, Mechanical/AP/DA/MA/CentraAir models	9493-0007
C	Catch, DH/EH/H/HP/VH models	9493-0015

Subject: Tough Strut Upgrade

Conversion to Current Design

In order to convert early Tough Strut supports to the current design, a portion of the base weldment must be trimmed/removed, and a DH/EH/H/HP/VH catch assembly (part number 9493-0015) must be purchased.

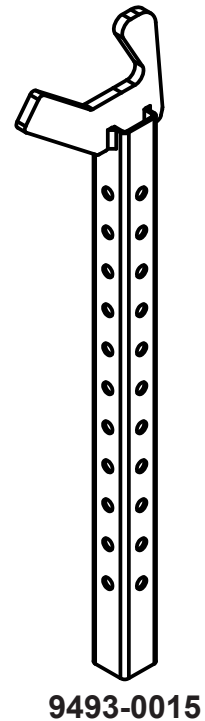
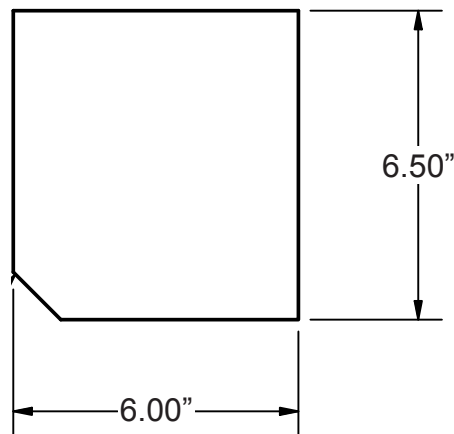
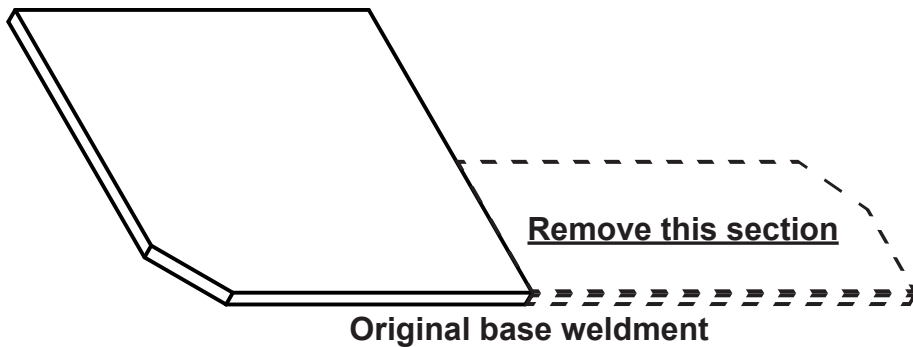

After the original base weldment has been trimmed and the additional catch assembly has been purchased, the Tough Strut can be used on Mechanical, AP, DA, MA and CentraAir units with catch 9493-0007, and on DH, EH, H, HP and VH models with catch 9493-0015.*

*Tough Strut not compatible with PR model hydraulic dock levelers.