

TPR UniLock® Retrofit

INCREASE PRODUCTIVITY

Don't waste time reversing trucks to release RIG Wedge pressure. Upgrade a TPR to the UniLock and have an advanced cam design that automatically releases RIG Wedge. Save time and increase efficiency.

INCREASE SAFETY

When servicing trailers with obstructed Rear Impact Guards, such as intermodal trailers with cover plates, upgrade to the UniLock to ensure a secure engagement is always maintained utilizing the new internal safety mechanism that locks the hook in place.



Upgrade
an Existing TPR®
to the **NEW UniLock®**

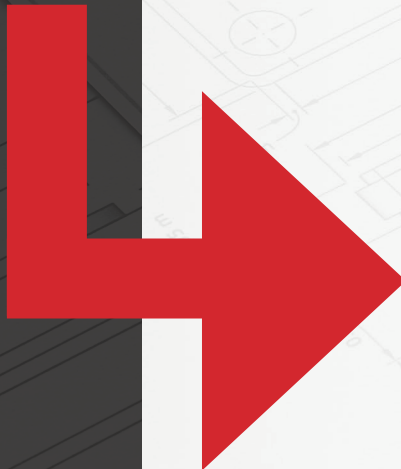

Value Engineered
Dock Levelers

TPR UniLock® Retrofit

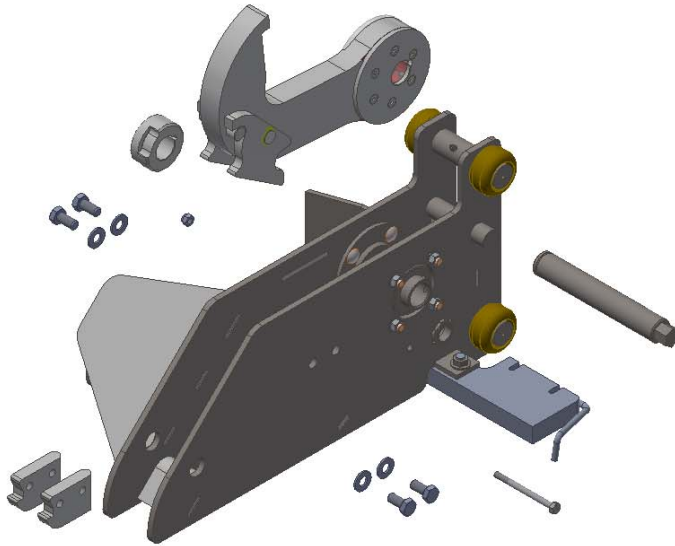

BEFORE SEPTEMBER 2017

Kit Includes
UniLock Carriage (fully assembled)
UniLock Hook (fully assembled)
Timer Control (control box part)
Timer Socket

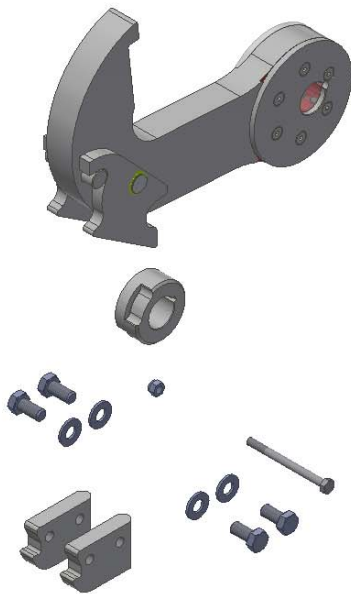

SEPTEMBER 2017 AND AFTER

Kit Includes
UniLock Hook (partially assembled)
Hardware and Hook Components
Timer Control (control box part)

TPR UniLock Retrofit Kits require disassembly of existing TPR units and the installation of all necessary components in the kits above. Retrofit kits for original TPR units purchased after September, 2017 cannot be used with TPR units purchased prior to September, 2017. Please contact a DLM representative for TPR units purchased in September, 2017. Decals are provided with each retrofit kit and are of the installer's responsibility to apply each decal after installation is complete.

W194N11481 McCormick Dr. | Germantown, WI 53022
dlmdocks.com | sales@dlmdocks.com
800-643-5424



dlmdocks.com

Designed, Engineered, and Manufactured in the U.S.A.
© 2024 Systems, LLC/DLM
Consistent with our policy of continuing product improvement, we reserve the right to change product specifications without notice or obligation.

UNILOCK RETRO 12/2024

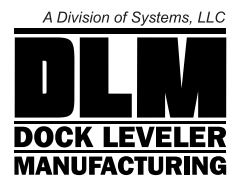

Value Engineered
Dock Levelers