

PowerStop® Automatic Vehicle Restraint

Specification Sheet & Submittal

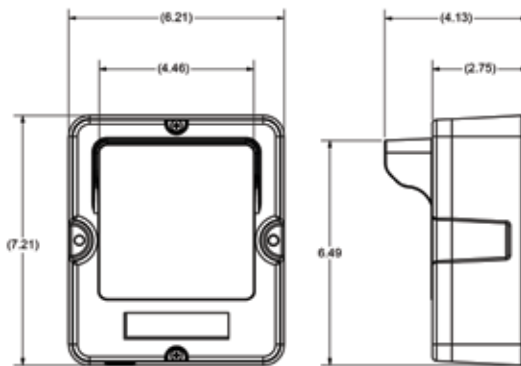

OSLA (Outside Light Assembly)

Inside Signage



Outside Signage

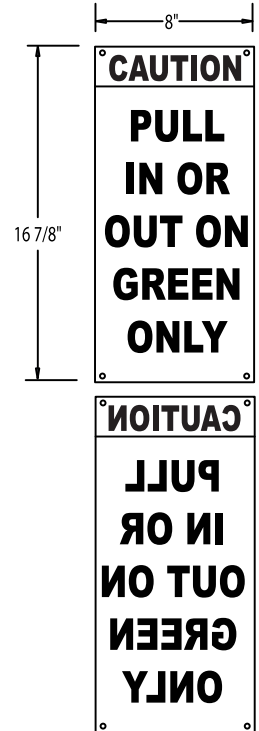

Standard Features

Push-button activation (115v single-phase operation)	RIG sensor bar notifies the operator if the restraint is not securely engaged to the trailer's Rear Impact Guard
iDock® 2.0 Controls with dynamic message display	Zinc-plated for maximum corrosion resistance
Advanced 3-color light communication	Automatically ensures safe capture or auto-stores
Low profile, non-impact design (wall or driveway mount)	Automatically re-engages if the restraint is forced down
Remote power pack with translucent reservoir	iDock 2.0 Controls connected online with optional myQ® Enterprise
Restraining force in excess of 32,000 lbs.	Designed and manufactured in the USA

General Description

All DLM Docks PowerStop® Automatic Truck Restraints (AAL) are designed to secure a cargo trailer's Rear Impact Guard (RIG) to reduce the likelihood of premature trailer separation during the loading process. The exclusive PowerStop® vehicle restraint features a hydraulic restraint mechanism with power package, inside iDock control panel, exterior communication lights and instructional signs.

Exterior Lights

Low-profile exterior lights are standard with LED for extended life. One light shows a red X and a green circle for color-impaired individuals. A set of caution signs warns truck drivers to "Pull in or out on green only".



Construction

The PowerStop® (AAL) restraint system is designed to be a stationary mount, non-impact device, permanently mounted to loading dock foundation or drive approach. Restraint is preserved in a zinc finish for all weather protection. Restraint arm is preserved in a highly visible zinc dicromate finish that is highly resistant to corrosion and protected by a bellow style cover to eliminate the accumulation of debris. Once activated, the PowerStop® extends upward to the RIG. The locking restraint arm secures the trailer with over 32,000 lbs. of pull-out force. The fully automatic PowerStop® is affordable and easy to install. It is ideal for all manufacturing, warehouse and distribution applications.

Hydraulics

The PowerStop® is a hydraulically actuated restraint with an iDock Alert communication system. The PowerStop® vehicle restraint raises vertically to find and maintain a hold on the RIG of truck throughout loading and unloading operations. The dual locking restraint arm will minimize “trailer creep”. As an optional safety feature, the dock leveler and the vehicle restraint can be interlocked, preventing operation of the dock leveler until the restraint is activated.

Hooking Range & Capacity

The PowerStop® restraint can withstand a pulling force in excess of 32,000 lbs., giving an added margin of safety and protection. Maximum operational range is 10” horizontally from face of dock bumpers, and 12” minimum to 29¼” maximum vertically. Additional ranges are available for certain applications.

Operation

As a trailer backs into position, the exterior light is green and the interior light is red. Once the trailer is positioned against the dock bumpers, the operator presses the “Engage” button. The PowerStop® raises vertically to the RIG and the inside light will display green while the outside light will display red. The dock attendant should

visually inspect and confirm that the restraint has engaged the horizontal member of the RIG. If the restraint is not securely engaged to the trailer’s RIG, the inside light will change to red and an optional audible alarm will sound. After the loading is complete, the operator presses the release button. When the trailer is released and the restraint is safely stored the interior light changes to red while the exterior light changes to green.

If the PowerStop is unable to secure the trailer’s RIG, the restraint will communicate the fault condition on the message display and by flashing an amber caution light. If bypass of the system is necessary, it is recommended that you secure the trailer by other means before proceeding with the loading/unloading process.

Electrical

The PowerStop® vehicle restraint is available as a stand alone unit or combined electrically and/or hydraulically with your dock leveler selection. Hydraulic pump and motor is 1/4 HP requiring 4.6 Amps at 115v single phase. Electrical control panel is a NEMA 4x enclosure. All electrical control panel components, connections and wiring are UL listed/ recognized.



Please Note: Unless specifically noted on quotation, all electrical requirements, including mounting of control box, outside lights and signs, are the responsibility of others.

Warranty

All PowerStop® vehicle restraints feature a full one (1) year base warranty on all structural, hydraulic and electrical parts, including freight and labor charges in accordance with Systems, LLC’s Standard Warranty Policy. Systems, LLC warrants all components to be free of defects in materials and workmanship, under normal use, during the warranty period. This base warranty period begins upon the completion of installation or the sixtieth (60th) day after shipment, whichever is earlier.

Order Specifications

Optional Equipment

- Integrated Control Panel (effects panel size)
- iDock 1.0 Controller (see 1.0 literature)
- Dock Leveler Interlock
- Limit Switch for Door Interlock
- Combined Power Source (VH and PR Series Only)
- Audible Alarm
- Additional Interlock Terminals
- Cantilever Bracket _____ Projection
- Low Profile 10”

Check Options Desired

- Standard 24” Hose Length
- Extended Hose Length _____
- Embed Plate _____ Wall _____ Drive
- Anchor Pkg _____ Wall _____ Drive
- Other _____
- Other _____
- Other _____

*options must also be selected on the iDock Controls Specification Sheet.

Required Information

CUSTOMER	_____
JOB	_____
LOCATION	_____
NUMBER OF UNITS	_____
MODEL	_____
SIZE	_____
REPRESENTED BY	_____
SALES REP	_____

Certified for Construction

BY	_____
DATE	_____
COMPANY	_____
CITY & STATE	_____
DRAWING #	_____