

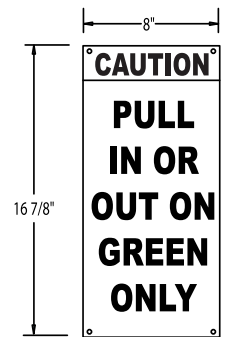

iDock® Controls Specification Sheet and Submittal

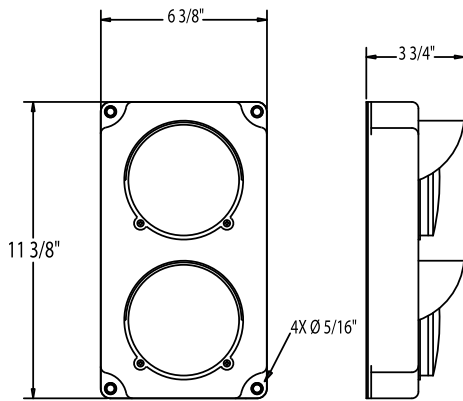

STANDARD FEATURES FOR iDOCK CONTROLS

- Advanced Controls of Loading Dock Equipment
- Interactive Message Display with System Information
- View Equipment Usage and Maintenance History
- Raised Dome Button Design for Ease of Use
- Fault Code Troubleshooting Display and Internal LED Lights
- Optional Integrated Controls of all DLM Dock Equipment and Dock Door Installed
- 3-Color Light Communication System
- LED Interior and Exterior Lights
- UL 4X Nonmetallic Enclosure
- Made in the USA



iDock® Controls Specification Sheet and Submittal

GENERAL DESCRIPTION: iDock Controls are technologically advanced push-button controllers and light communication used with various Poweramp loading dock equipment. iDock Controls are standard with all automatic Poweramp vehicle restraints, used with or without dock levelers.

CONSTRUCTION: iDock Controls are made with UL 4X Nonmetallic enclosures. The controls feature a modular design to reduce maintenance costs. 3-in-1 light assembly on the controller shows the state of the station and whether it is safe to enter the trailer. LCD display shows status of controls and explains fault conditions. Metal dome buttons provide positive feedback to the controls.

MESSAGE DISPLAY: iDock Controls feature an LCD interactive message display for equipment information, system information, maintenance history, counters and settings. The operator presses the Menu button, then up and down arrows to navigate through the menu. Press Enter to advance one screen, or Menu to go back. The Message Display will also provide notices of faults, or instructions for Bypass mode or a sequence of operation.

EXTERIOR LIGHTS: Low profile, traffic style, red and green LED lights opposite of interior lights are standard for communication to the truck driver. A set of caution signs warns the truck driver to "Back In or Pull Out On Green Light Only".

WARRANTY: iDock Controls feature a full one (1) year base warranty on all structural, mechanical and electrical parts, including freight and labor charges in accordance with Systems, LLC's Standard Warranty Policy. Systems, LLC warrants all components to be free of defects in materials and workmanship, under normal use, during the warranty period. This base warranty period begins upon the completion of installation or the sixtieth (60th) day after shipment, whichever is earlier.

Integrated Control Panel Shown (Standard Size)



Equipment and Options with iDock Controls (Select all that apply)		
RESTRAINTS	LEVELERS	INTERLOCKING (Select one)
<input type="checkbox"/> TPR UniLock® <input type="checkbox"/> TPR® <input type="checkbox"/> PowerStop® AAL <input type="checkbox"/> PowerStop® MAL <input type="checkbox"/> Light Communication Only - See OPTIONS	<input type="checkbox"/> Hydraulic Pit Leveler _____ Series <input type="checkbox"/> Pneumatic Pit Leveler _____ Series <input type="checkbox"/> Edge-of-Dock _____ Series <input type="checkbox"/> Mechanical Leveler _____ Series	<input type="checkbox"/> None <input type="checkbox"/> (1) Restraint Engaged Before Leveler Operate <input type="checkbox"/> (2) Restraint Engaged Before Door Open <input type="checkbox"/> (3) Leveler Stored Before Restraint Release <input type="checkbox"/> (4) Leveler Stored Before Door Closed <input type="checkbox"/> (5) Door Open Before Restraint Engage <input type="checkbox"/> (6) Door Closed Before Restraint Release <input type="checkbox"/> Combination 1/3 <input type="checkbox"/> Combination 2/6 <input type="checkbox"/> Combination 1/2/3/4/6 <input type="checkbox"/> Combination 5/1/3/4 <input type="checkbox"/> Combination 1/3/4
OPTIONS (Select all that apply)		
<input type="checkbox"/> Audible Alarm <input type="checkbox"/> Emergency Stop Push Button <input type="checkbox"/> Independent Lip Control <input type="checkbox"/> Below Dock End Cycle Control (Requires Independent Lip Controls) <input type="checkbox"/> Close Door to Reset Lights <input type="checkbox"/> Leveler Stored Indication Light <input type="checkbox"/> LiftMaster Logic 5.0 Maintenance System Monitoring <input type="checkbox"/> Light Communication System (Select One) <input type="radio"/> Manual Control <input type="radio"/> Automatic Control with Leveler Position <input type="radio"/> Automatic Control with Door Position <input type="checkbox"/> 3-Button Door Controls <input type="checkbox"/> Dock Light (Select One) <input type="radio"/> Manual Control (On/Off) <input type="radio"/> Automatic Control with Door Position <input type="radio"/> Automatic Control with Leveler Position <input type="checkbox"/> Edge Light Controls <input type="checkbox"/> Guide Light Controls (1 Light or 3 Light)	<input type="checkbox"/> Sensor <input type="radio"/> Fluid Level <input type="radio"/> Forklift Activity <input type="radio"/> Vehicle Present <input type="checkbox"/> Signal to External Equipment (Dry Contact) <input type="radio"/> Restraint Engaged or in Bypass <input type="radio"/> Leveler Stored <input type="radio"/> Vehicle Present <input type="checkbox"/> External Equipment Interlocking (Signal to Allow Operation) (Select One) <input type="radio"/> Prevent Leveler Operation <input type="radio"/> Prevent Door Operation <input type="radio"/> Restraint Release <input type="radio"/> All Operation (All 3 of the Above) <input type="checkbox"/> Disconnect (Select One) <input type="radio"/> Rotary Fused <input type="radio"/> Rotary Non-Fused <input type="radio"/> Flange Fused <input type="radio"/> Flange Non-Fused <input type="checkbox"/> Receptacle	VOLTAGE (Select one) <input type="checkbox"/> 115V / 1PH / 60HZ <input type="checkbox"/> 208V / 1PH / 60HZ <input type="checkbox"/> 230V / 1PH / 60HZ <input type="checkbox"/> 208V / 3PH / 60HZ <input type="checkbox"/> 230V / 3PH / 60HZ <input type="checkbox"/> 460V / 3PH / 60HZ <input type="checkbox"/> 575V / 3PH / 60HZ <input type="checkbox"/> 230V / 1PH / 50HZ <input type="checkbox"/> 400V / 3PH / 50HZ

⚠ WARNING: Product may expose you to chemicals known to the state of California to cause cancer or reproductive harm. www.P65Warnings.ca.gov

Customer: _____ Job: _____ Location: _____ Number of Units: _____ Represented By: _____ Sales Rep: _____	Certified for Construction: By: _____ Date: _____ Company: _____ City State: _____ Drawing #: _____
---	--

A continuing product improvement process is in effect at Systems, LLC We reserve the right to make product changes without prior notice.